

## B-Series

---

### *Dimension and Selection Guide*



**1.800.255.3416**

---



Canada: 100% OUTSIDE AIR ONLY

# B-350 Upright Model Dimensions

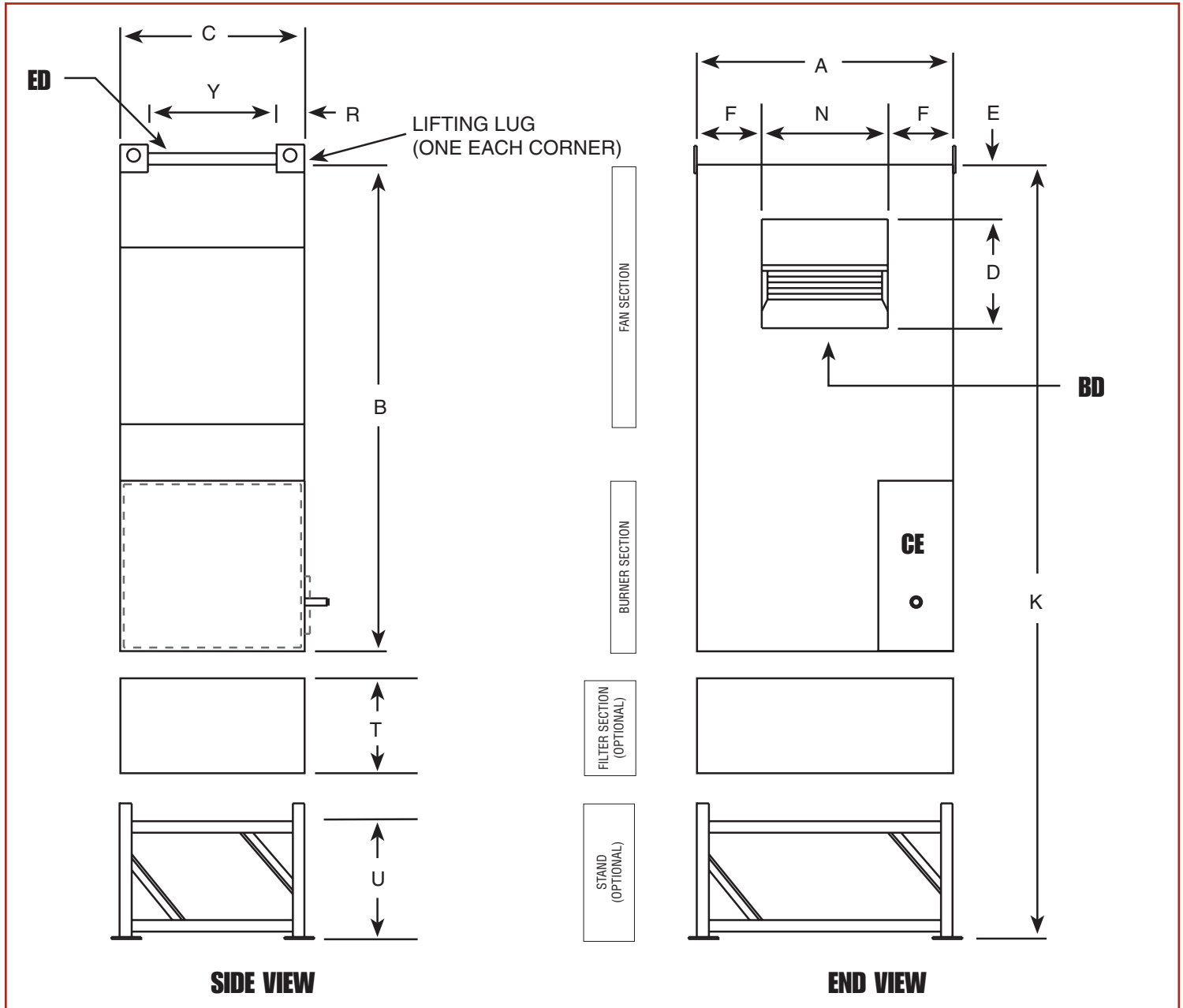

LEGEND
<b>BD</b> = Bottom Discharge
<b>BR</b> = Bottom Return
<b>CE</b> = Control Enclosure
<b>ED</b> = End Discharge
<b>OA</b> = Outside Air
<b>RA</b> = Return Air
<b>UD</b> = Up Discharge

## IMPORTANT NOTES:

- All dimensions are in inches.
- All weights are in pounds.
- Shipping weights apply to both horizontal and upright models.
- All dimensions and weights are subject to change without notice.
- Stands and filter sections are shipped separate.
- Outdoor air duct size varies. Consult Bananza.

# B-350 Horizontal Model Dimensions

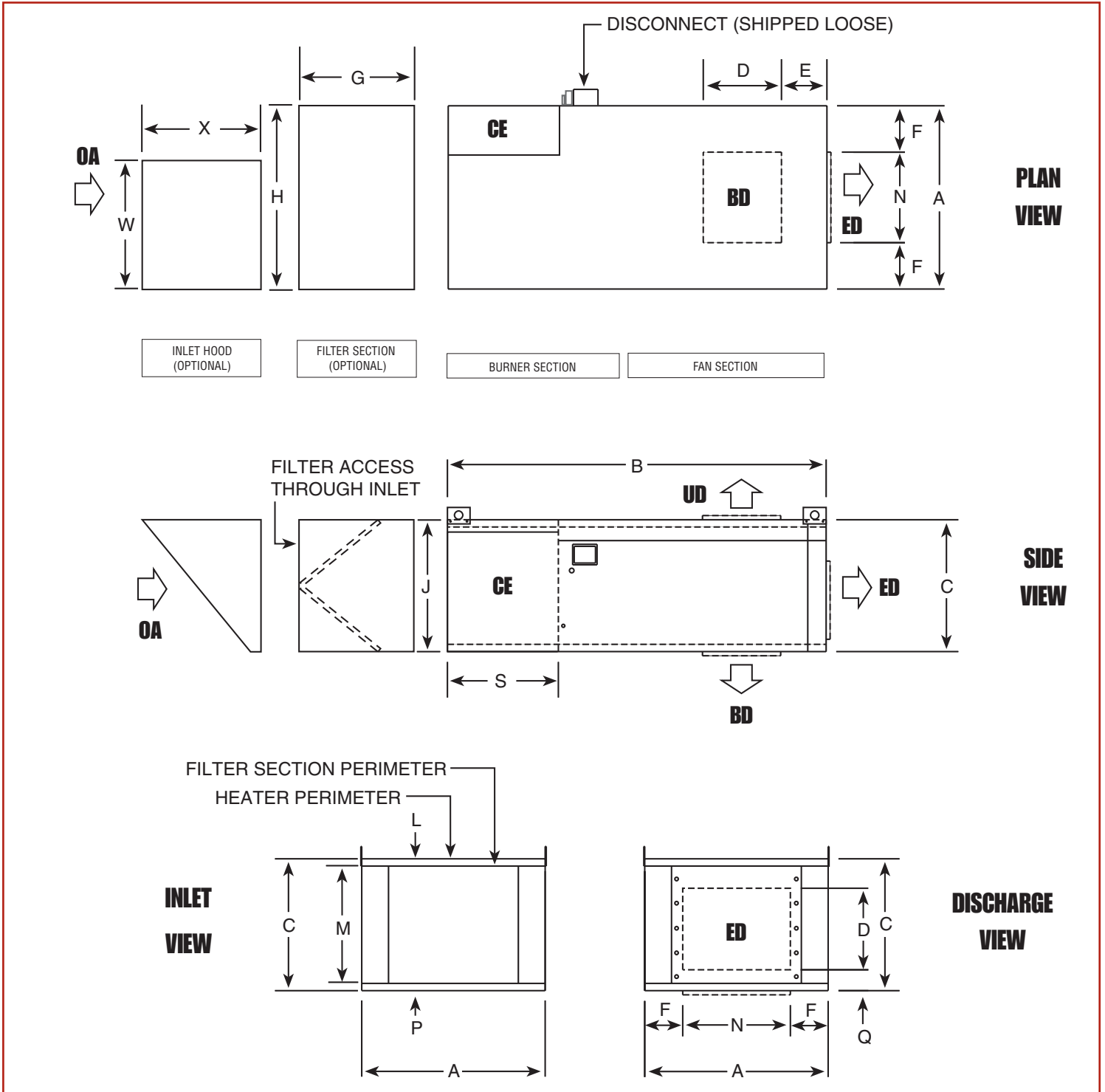

INLET HOOD FILTERS	
MODEL	QUANTITY
B-350	2 - 25 x 20 x 1 -or- 2 - 25 x 20 x 2

ESTIMATED SHIPPING WEIGHTS		
MODEL	AIR HANDLER	STAND
B-350	450	40

CABINET DIMENSIONS																							
MODEL	A	B	C	D	E	F	G	H	J	K	L	M	N	P	Q	R	S	T	U	V	W	X	Y
B-350	32.5	60.5	28.1	13.6	7.5	8.3	27.1	32.4	28.1	117.9	1.5	25.0	15.6	1.6	2.9	3.0	28.3	27.1	30.3	38.4	25.0	38.4	22.1

# B-650, B-1000, B-2000 & B-3000 Upright Model Dimensions

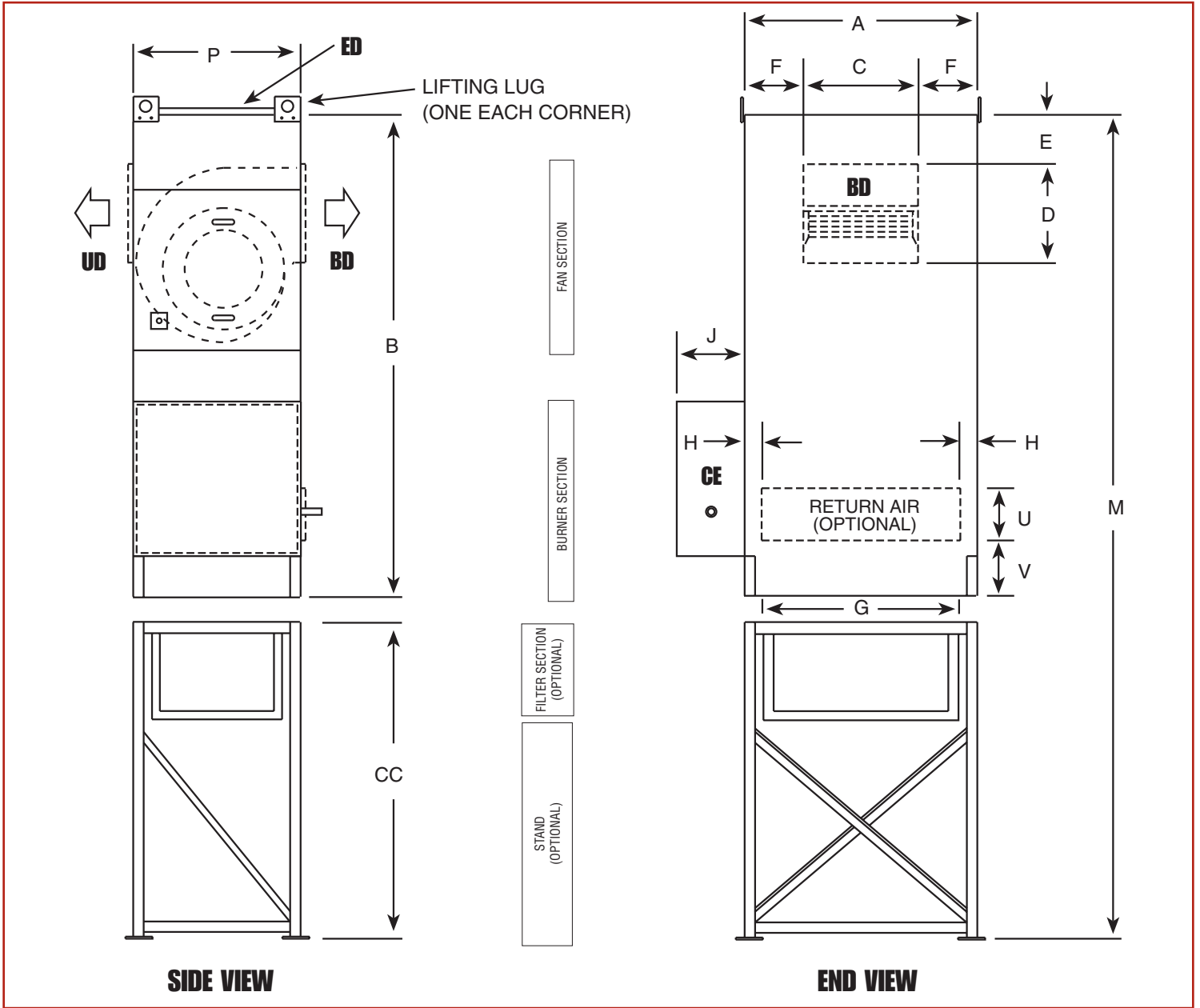

LEGEND	
<b>BD</b>	= Bottom Discharge
<b>BR</b>	= Bottom Return
<b>CE</b>	= Control Enclosure
<b>ED</b>	= End Discharge
<b>OA</b>	= Outside Air
<b>RA</b>	= Return Air
<b>UD</b>	= Up Discharge

## IMPORTANT NOTES:

- All dimensions are in inches.
- All weights are in pounds.
- Shipping weights apply to both horizontal and upright models.
- All dimensions and weights are subject to change without notice.
- Stands and filter sections are shipped separate.
- Outdoor air duct size varies. Consult Bananza.

# B-650, B-1000, B-2000 & B-3000 Horizontal Model Dimensions

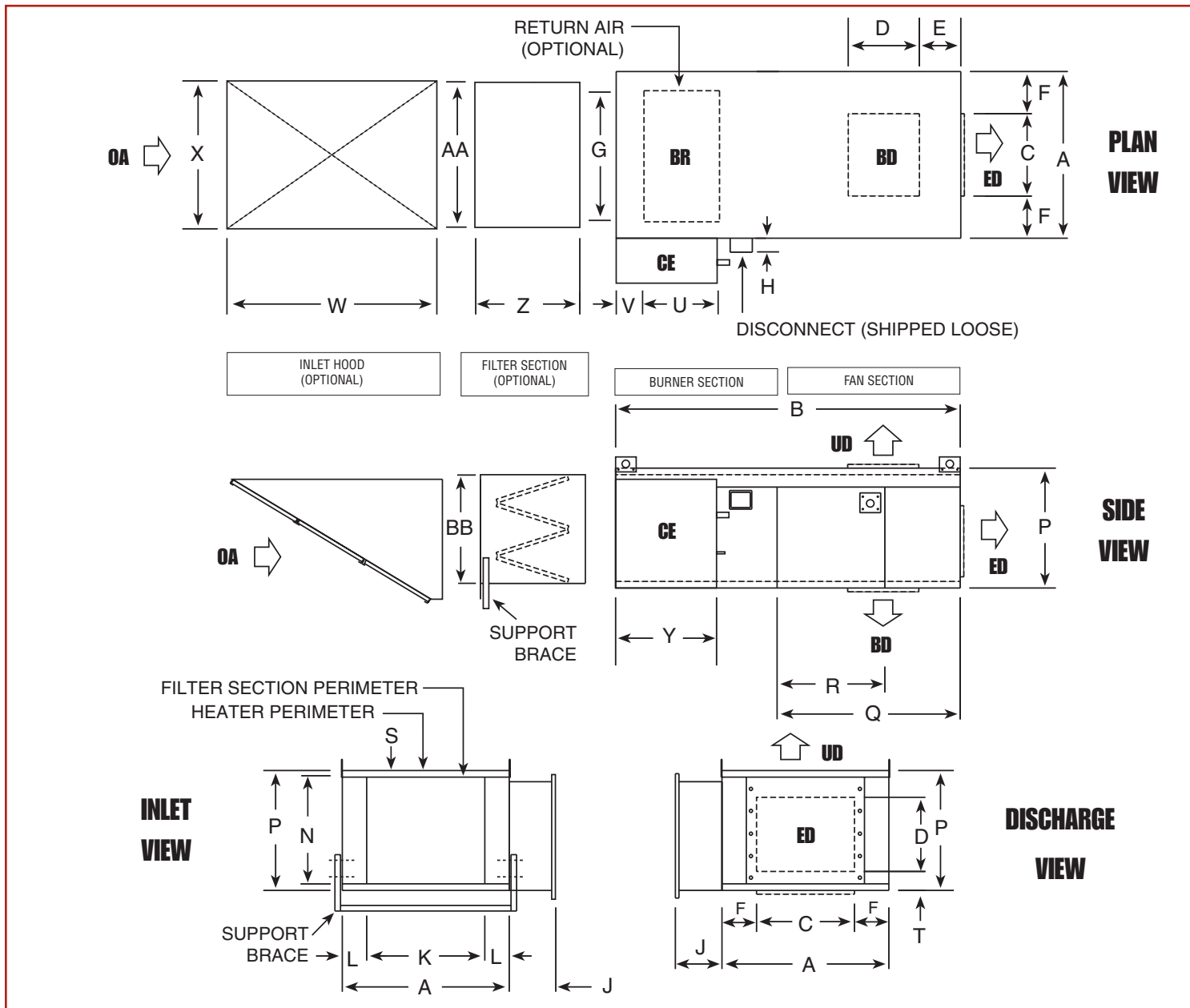

B-2000 BOTTOM RA INLET	
CFM	U
12,000	8.0
14,000	10.0
16,000	10.0
18,000	12.0
20,000	12.0
22,000	14.0
25,000	16.0

INLET HOOD FILTERS	
MODEL	QUANTITY
B-650/ B-1000	6 - 20 x 20 x 1
B-2000	12 - 20 x 20 x 1
B-3000	12 - 20 x 20 x 1 -plus- 4 - 20 x 10 x 1

ESTIMATED SHIPPING WEIGHTS						
MODEL	AIR HANDLER	STAND	INLET HOOD	SUSP. KIT	SPLASH PLATE	SKID
B-650/ B-1000	700	140	60	30	50	140
B-2000	1400	175	120	30	60	340
B-3000	1650	210	240	80	90	365

CABINET DIMENSIONS																											
MODEL	A	B	C	D	E	F	G	H	J	K	L	M	N	P	Q	R	S	T	U	V	W	X	Y	Z	AA	BB	CC
B-650/ B-1000	44.5	92.0	22.0	19.0	11.0	11.3	38.0	3.3	13.0	31.5	6.5	166.3	28.5	32.0	47.8	34.8	1.8	3.0	10.0	3.0	56.0	39.5	35.0	28.0	38.8	29.0	74.3
B-2000	56.0	116.0	31.5	31.5	14.0	12.3	50.0	3.0	13.0	50.0	3.0	190.3	52.3	56.0	71.5	39.5	1.8	4.0	*	3.0	63.0	59.0	35.0	30.0	52.5	53.0	74.3
B-3000	68.0	116.0	36.5	36.5	17.0	15.8	62.0	3.0	17.0	60.0	4.0	190.2	42.5	60.3	68.0	28.5	3.3	4.0	24.0	3.0	71.0	67.0	44.0	40.0	80.0	56.0	74.3

\*Dimension varies with CFM. See "B-2000 Bottom Return Air Inlet" Dimensions Table.

# B-4000 & B-5000 Upright Model Dimensions

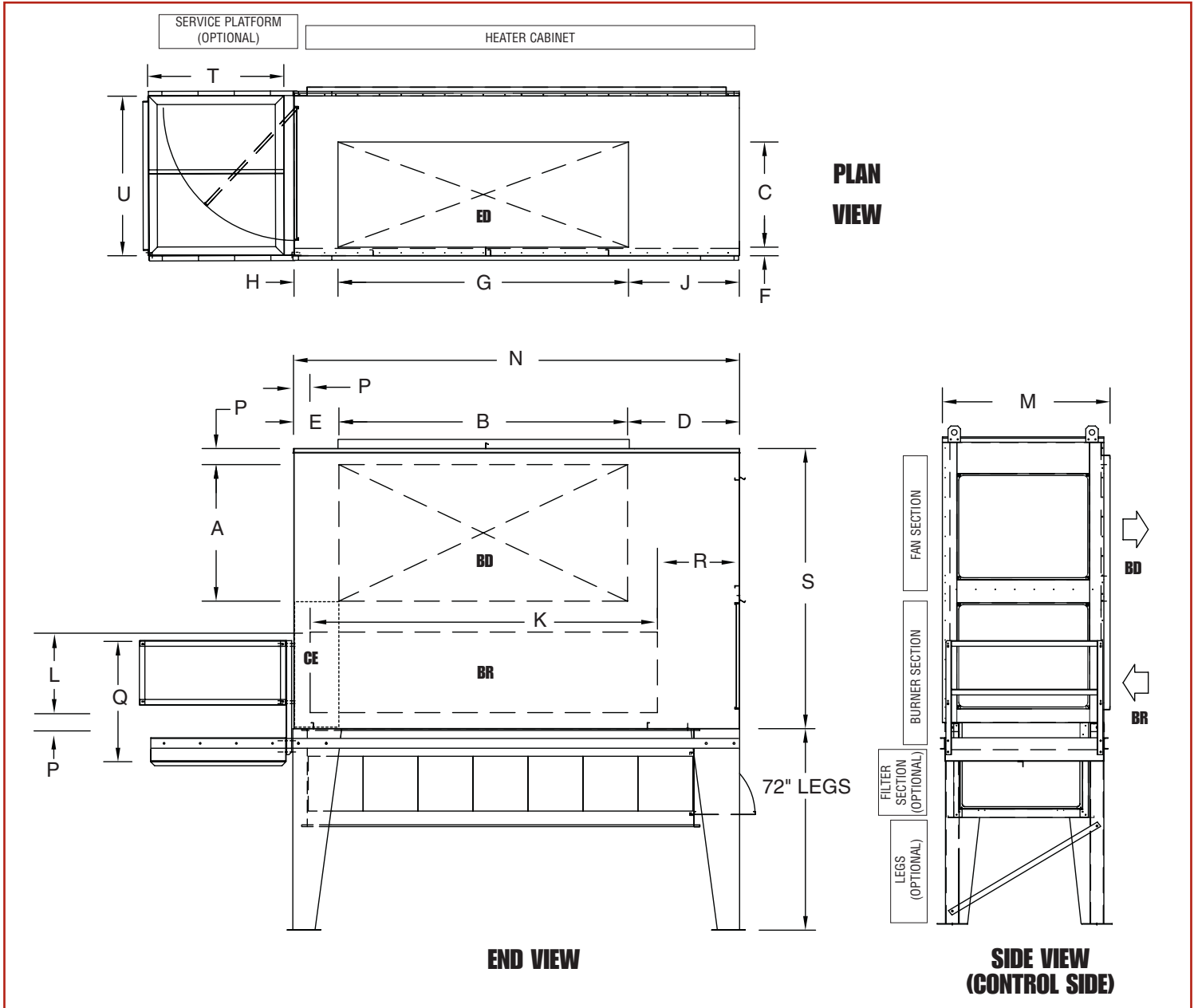

LEGEND	
<b>BD</b>	= Bottom Discharge
<b>BR</b>	= Bottom Return
<b>CE</b>	= Control Enclosure
<b>ED</b>	= End Discharge
<b>OA</b>	= Outside Air
<b>RA</b>	= Return Air
<b>UD</b>	= Up Discharge

## IMPORTANT NOTES:

- All dimensions are in inches.
- All weights are in pounds.
- Shipping weights apply to both horizontal and upright models.
- All dimensions and weights are subject to change without notice.
- Filter sections are shipped separate.
- Legs are shipped loose.
- Outdoor air duct size varies. Consult Bananza.
- Filter section requires independent support. Available by Bananza (optional).

# B-4000 & B-5000 Horizontal Model Dimensions

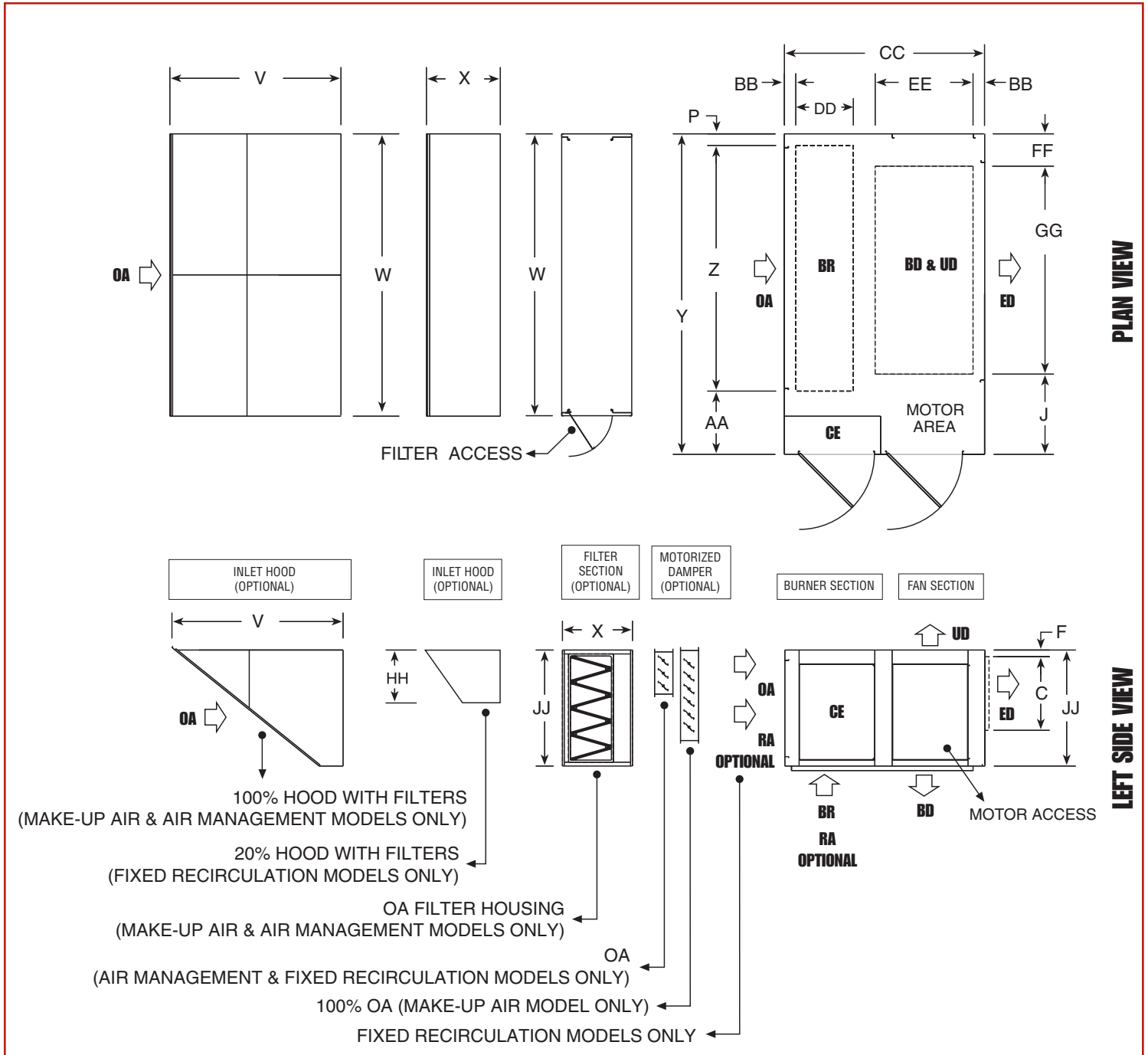

CABINET DIMENSIONS													
MODEL	A	B	C	D	E	F	G	H	J	K	L	M	N
B-4000	42.5	90.0	32.0	47.0	23.0	12.0	86.5	23.8	48.5	125.0	31.0	60.25	160.4
B-5000	51.5	107.0	37.0	38.5	14.5	3.0	104	15.8	40.0	125.0	31.0	60.25	160.4

ESTIMATED SHIPPING WEIGHTS		
MODEL	HEATER CABINET	INLET HOOD
B-4000	3,350	480
B-5000	3,800	480

CABINET DIMENSIONS (continued)																				
MODEL	P	Q	R	S	T	U	V	W	X	Y	Z	AA	BB	CC	DD	EE	FF	GG	HH	JJ
B-4000	5.8	43.0	29.3	100.1	49.0	57.0	86.0	137.5	35.0	160.0	122.5	31.6	5.0	100.0	28.7	39.7	25.0	88.0	26.4	58.0
B-5000	5.8	43.0	29.3	100.1	49.0	57.0	86.0	137.5	35.0	160.0	122.5	31.6	5.0	100.0	28.7	48.7	16.0	103.7	26.4	58.0

# B-4000 & B-5000 Selection Guide

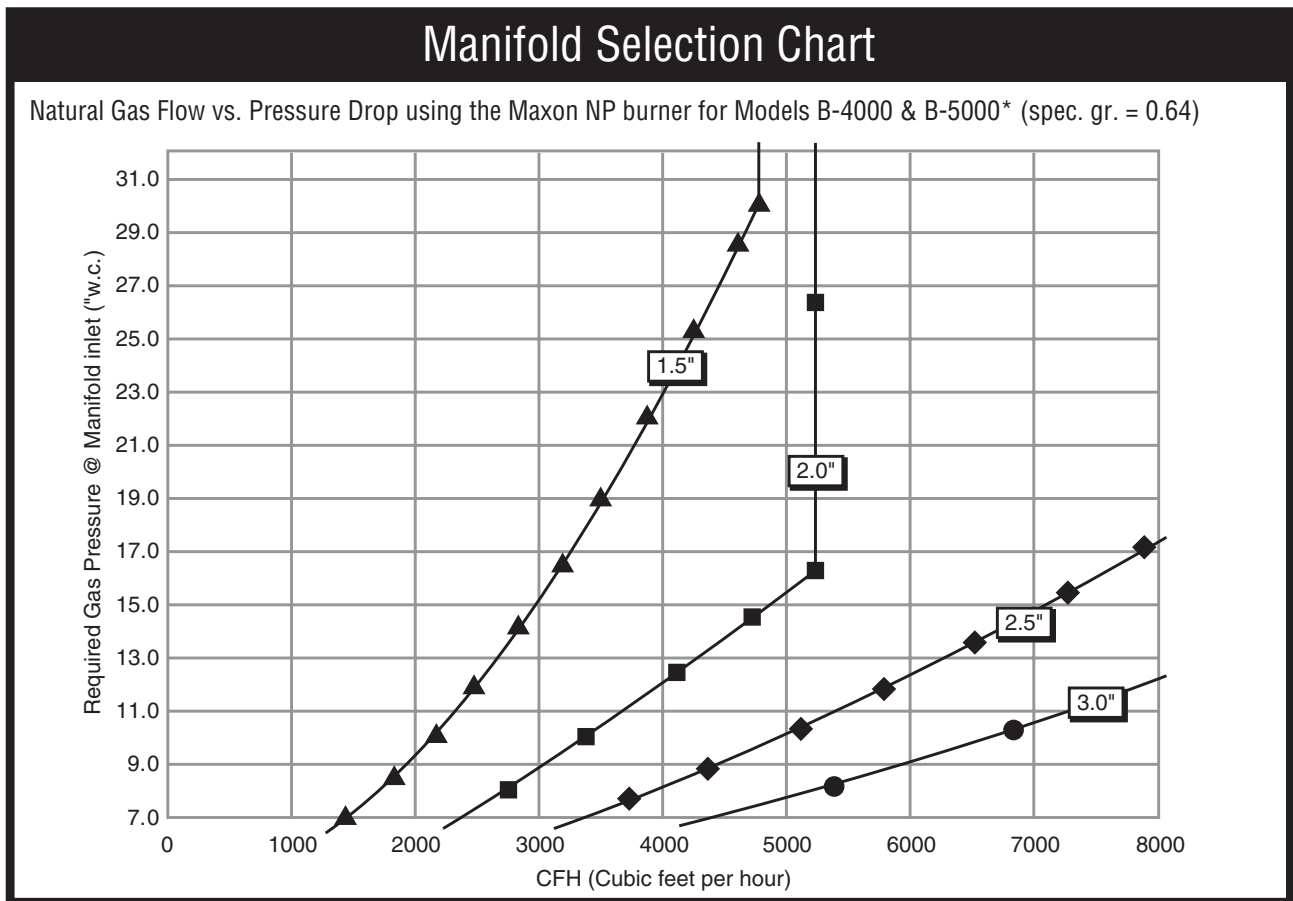

## DIRECTIONS:

- Select a point on the chart that represents the intersection of the inlet gas pressure and the desired CFH.
- Select the manifold size to the right of this point.

\*NOTE: For other models, see Page 9 for manifold sizes.



# B-Series Selection Guide

CFM	Model	MOTOR CHART					dB "A" @ noted External Static Pressure			BURNER CHART MBH @ 100°F	GAS PRESSURE	MANIFOLD SIZE
		Required Motor HP @ noted External Static Pressure					0.00	0.50	1.00		Minimum Inlet Gas Pressure (in. w.c.)	
		0.00	0.25	0.50	0.75	1.00						
1,000	B-350	2	2	2	2	2	62	66	70	110	7"	.75"
2,000	B-350	2	2	2	2	2	60	66	70	220	7"	.75"
3,000	B-350	3	3	3	3	3	60	65	70	330	7"	.75"
4,000	B-350	3	3	3	3	3	62	65	70	400*	7"	.75"
4,000	B-650	3	3	3	3	3	59	65	69	440	7"	1"
5,000	B-650	3	3	3	3	3	58	63	68	540	7"	1"
6,000	B-650	5	5	5	5	5	58	62	67	750	7"	1"
7,000	B-650	5	5	5	5	5	59	62	66	756	7"	1"
8,000	B-650	5	5	5	5	5	60	63	66	N/A	7"	1"
9,000	B-650	7.5	7.5	7.5	7.5	7.5	61	64	67	N/A	7"	1"
10,000	B-650	7.5	7.5	7.5	7.5	7.5	62	65	68	N/A	7"	1"
7,000	B-1000	5	5	5	5	5	59	62	66	760	7"	1.25"
8,000	B-1000	5	5	5	5	5	60	63	66	870	7"	1.25"
9,000	B-1000	7.5	7.5	7.5	7.5	7.5	61	64	67	980	7"	1.25"
10,000	B-1000	7.5	7.5	7.5	7.5	7.5	62	65	68	1080	7"	1.25"
11,000	B-1000	10	10	10	10	10	64	66	68	1190	7"	1.25"
12,000	B-1000	10	10	10	10	10	66	68	69	1300	7"	1.25"
13,000	B-1000	10	10	10	10	N/A	67	69	N/A	1410	7"	1.25"
14,000	B-1000	10	10	N/A	N/A	N/A	69	N/A	N/A	1500*	7"	1.25"
12,000	B-2000	7.5	7.5	7.5	7.5	7.5	66	70	73	1300	9"	1.5"
14,000	B-2000	10	10	10	10	10	69	70	73	1520	9"	1.5"
16,000	B-2000	10	10	10	10	10	70	72	73	1730	9"	1.5"
18,000	B-2000	15	15	15	15	15	70	74	76	1950	9"	1.5"
20,000	B-2000	15	15	15	15	15	70	74	77	2160	9"	1.5"
22,000	B-2000	20	20	20	20	20	71	74	77	2380	9"	1.5"
25,000	B-2000	20	20	20	20	20	72	75	77	2700	9"	1.5"
25,000	B-3000	15	15	15	15	15	70	72	74	2700	11"	2"
27,500	B-3000	15	15	15	15	15	71	73	75	2970	11"	2"
30,000	B-3000	20	20	20	20	25	73	75	76	3240	11"	2"
32,500	B-3000	20	20	20	20	25	75	76	77	3510	11"	2"
35,000	B-3000	20	25	25	25	25	77	77	79	3780	11"	2"
37,500	B-3000	25	25	30	30	30	78	79	N/A	4050*	11"	2"
40,000	B-3000	30	30	30	N/A	N/A	80	N/A	N/A	4100*	11"	2"
35,000	B-4000	15	20	20	25	25	68	73	77	3780	Refer to Manifold Selection Chart	
37,500	B-4000	20	20	25	25	30	69	73	77	4050		
40,000	B-4000	20	25	25	30	30	70	73	77	4320		
42,500	B-4000	25	25	30	30	40	71	74	77	4590		
45,000	B-4000	30	30	30	40	40	72	74	77	4860		
47,500	B-4000	30	40	40	40	40	73	75	78	5130		
45,000	B-5000	20	20	25	25	30	72	74	77	4860		
47,500	B-5000	20	25	25	30	30	73	75	77	5130		
50,000	B-5000	25	25	30	30	40	74	75	77	5400		
52,500	B-5000	25	30	30	40	40	74	76	78	5670		
55,000	B-5000	25	30	40	40	40	75	77	78	5940		
57,500	B-5000	30	40	40	40	40	76	78	79	6210		
60,000	B-5000	30	40	40	40	50	77	78	80	6480		

\* Temperature rise at this CFM is less than 100°F.

If the inlet hood with filters option is used, add 0.25" w.c. for external static pressure.

Maximum Inlet Gas Pressure with a Standard manifold is 14" w.c. Maximum Inlet Gas Pressure with a FM / IRI manifold is 5 psi.

Db "A" is measured at 10' from unducted discharge.

# Discharge Heads

## ONE-WAY DISCHARGE HEAD

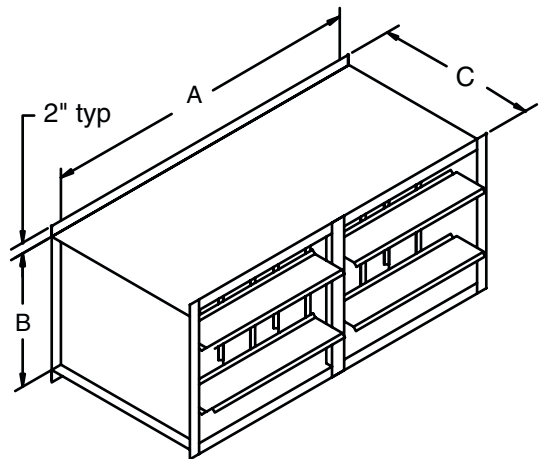

(Available on B-4000 and B-5000 Models Only.)

## THREE-WAY DISCHARGE HEAD

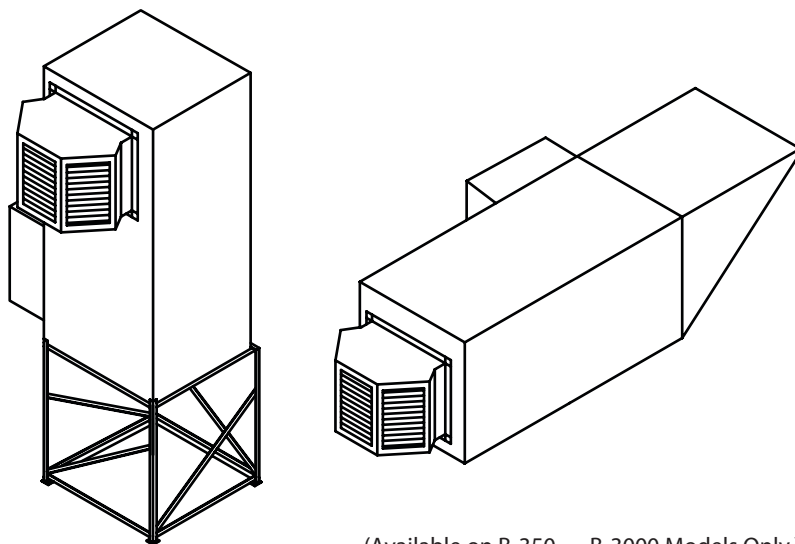

(Available on B-350 — B-3000 Models Only.)

## IMPORTANT NOTES:

- All dimensions are in inches.
- All weights are in pounds.
- All dimensions and weights are subject to change without notice.
- Outdoor air duct size varies. Consult Bananza.

DISCHARGE HEADS					
MODEL	A	B	C	D	WEIGHT
B-350	19.0	40.75	23.75	21.0	45
B-650	22.4	40.75	24.0	19.4	80
B-1000	22.4	40.75	24.0	19.4	80
B-2000	31.9	43.25	21.5	33.9	120
B-3000	36.9	48.25	22.5	36.9	160
B-4000	87.75	39.8	30.0	-	215
B-5000	103.75	48.5	30.0	-	355

## THREE-WAY DISCHARGE HEAD

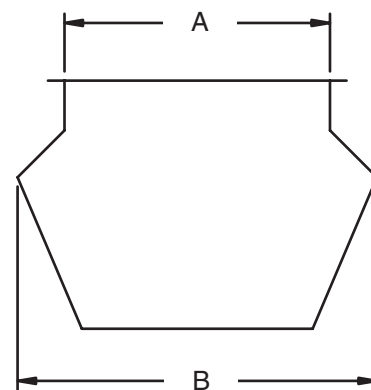

TOP VIEW

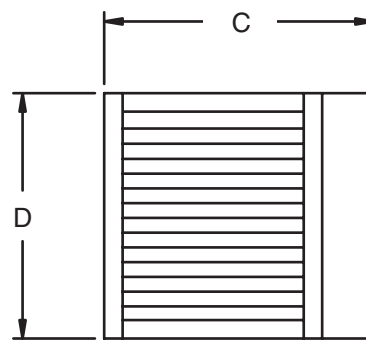

SIDE VIEW

(Available on B-350 — B-3000 Models Only.)

# Outside Air Filter Sections

**B-350 FILTER SECTION**

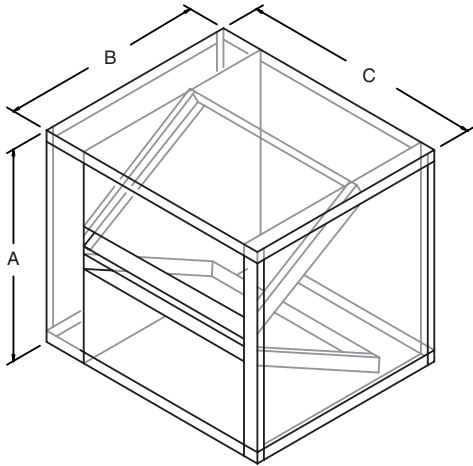

**B-1000 — B-3000 FILTER SECTION**

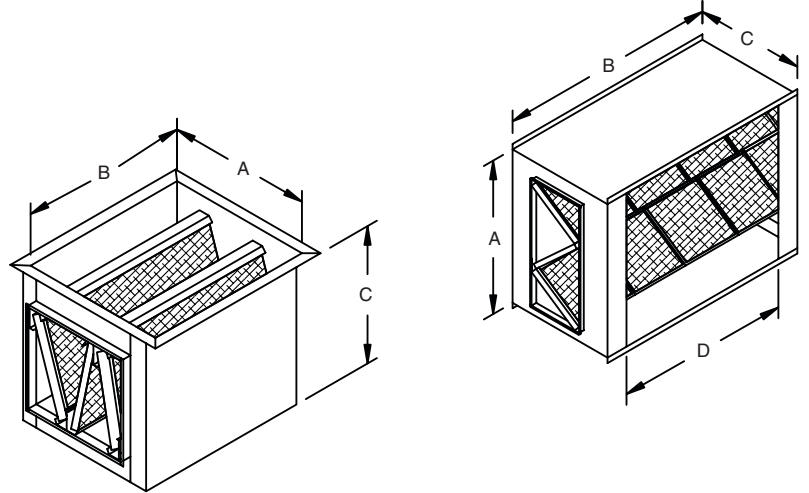

**B-4000 — B-5000 UPRIGHT FILTER SECTION**

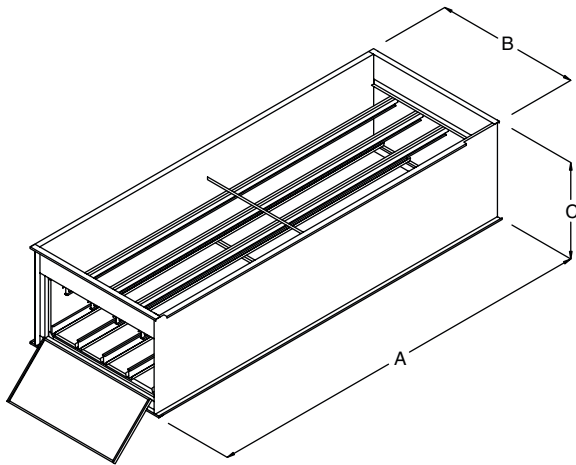

**B-4000 — B-5000 HORIZONTAL FILTER SECTION**

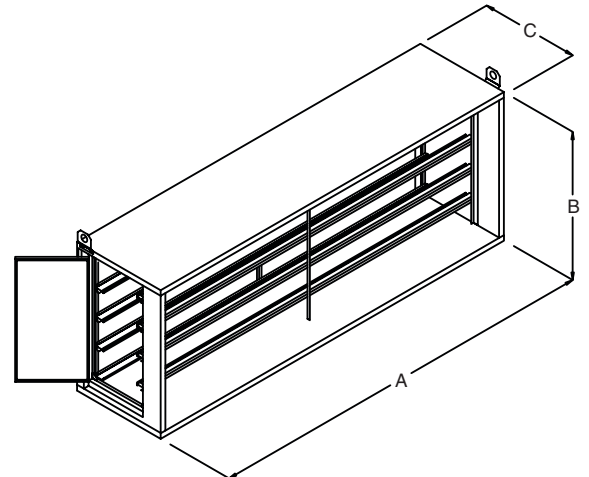

## IMPORTANT NOTES:

- All dimensions are in inches.
- All weights are in pounds.
- Shipping weights apply to both horizontal and upright models (where applicable).
- All dimensions and weights are subject to change without notice.
- Stands and filter sections are shipped separate.
- Outdoor air duct size varies. Consult Bananza.

MODEL	FILTER SECTION DIMENSIONS				FILTERS		ESTIMATED SHIPPING WEIGHTS (FILTER SECTION)
	A	B	C	D	SIZE	QTY	
B-350	28.1	27.1	32.3	-	20 x 25 x 2	2	100
B-650	29.0	38.8	28.0	-	20 x 20 x 1	6	60
B-1000	29.0	38.8	28.0	-	20 x 20 x 1	6	60
B-2000	53.0	52.5	30.0	-	20 x 25 x 1	10	140
B-3000 UPRIGHT	56.0	64.0	36.0	-	20 x 20 x 1 20 x 24 x 1	10 5	220
B-3000 HORIZONTAL	56.0	80.0	40.0	64.0	20 x 20 x 1	28	220
B-4000/B-5000 UPRIGHT	143.0	53.6	34.9	-	20 x 140	8	580
B-4000/B-5000 HORIZONTAL	137.4	57.9	34.0	-	20 x 140	8	580

# Thank You for Your Business!

---

## **Installation Code and Annual Inspections:**

All installations and service of BANANZA® products must be performed by a contractor qualified in the installation and service of products sold and supplied by Bananza and conform to all requirements set forth in the BANANZA® manuals and all applicable governmental authorities pertaining to the installation, service and operation of the equipment. To help facilitate optimum performance and safety, Bananza recommends that a qualified contractor annually inspect your BANANZA® products and perform service where necessary, using only BANANZA® replacement parts.

**Further Information:** Applications, engineering and detailed guidance on system design, installation and product performance is available through BANANZA® representatives. Please contact us for any further information you may require, including the Installation, Operation and Service Manual.

## **This product is not for residential use.**

This document is intended to assist licensed professionals in the exercise of their professional judgement.

## **Bananza**

1100 Seven Mile Road NW  
Comstock Park, MI 49321  
Telephone: 616.726.8800  
Toll Free: 800.255.3416  
Fax: 616.726.8807

**[www.bananza.com](http://www.bananza.com)**

© 2006 Roberts-Gordon, LLC      *All rights reserved. No part of this work covered by the copyrights herein may be reproduced or copied in any form or by any means – graphic, electronic, or mechanical, including photocopying, recording, taping, or information storage and retrieval systems – without written permission of Roberts-Gordon, LLC.*