

SPECIFICATION SHEET

Opera™-H



- Hoist-a-matic™ self engaging chain hoist
- Hinged cover with stable opened position
- Lifiable control box with retaining arm for easy access to mechanical parts
- Accu cam™ one hand limit setting

Opera-H, a heavy duty operator for high & vertical lift sectional doors or rolling doors and grilles. It can be wall, hood, or shelf mounted on either side of the door. It incorporates an automatic chain hoist for manual operation as well as several other innovations.

Opera-H

Jackshaft Operator

25 cycles/hour 100 cycles a day

• Construction

Continuous duty industrial motor (60 Hz)
 5L V-belt, chain and sprocket reduction
 #50 chain and sprocket on final drive
 1" output shaft with 1/4" keyway
 Operator sprocket: 50B12
 Output shaft speed: 41 rpm
 Mechanical brake
 Control box and limit shaft supported by frame
 Heavy duty reversing contactor
 Approximate shipping weight: 85 lbs. – 38.5 Kg

2 Year Warranty

• Easy Installation and Maintenance

Ergonomic packing, carrying handle
 Universal mounting
 Easy access to fixing holes
 Accu-cam™: quick limit setting by single hand operation
 Control box may be lifted and held in position
 Pivoting motor bracket
 Hinged cover with stable position
 Angled terminal strip

• Main Options

Hoist left mount
 Delay on reverse
 Timer to close
 Double limit
 Chain spreader

• Safety Features

Hoist-a-Matic™ : Hoist with automatic cut off (no need for a floor disconnect).
 Hand chain on right standard
 Adjustable friction clutch
 Full overload protection
 Unique fused control circuit protection



• Multi-Function 24V Safety Control Circuit

C2 wiring. B2 or D1 control can be set very easily by moving only one or two wires (see Manaras wiring diagram).

Pre-wired for open override, safety reverse, radio control wiring with external control strip.

• Operator range and current consumption (Amp.)

Horse Power	115 V 1 Ph	230 V 1 Ph	208/230 V 3 Ph	460 V 3 Ph	575 V 3 Ph
1/3*	6.6	3.3	-	-	-
1/2	8.0	4.0	2.1	1.0	0.8
3/4	11.2	5.6	3.2	1.5	1.2
1	13.6	6.8	4.4	2.1	1.6

*Only available in the US

Dimensions

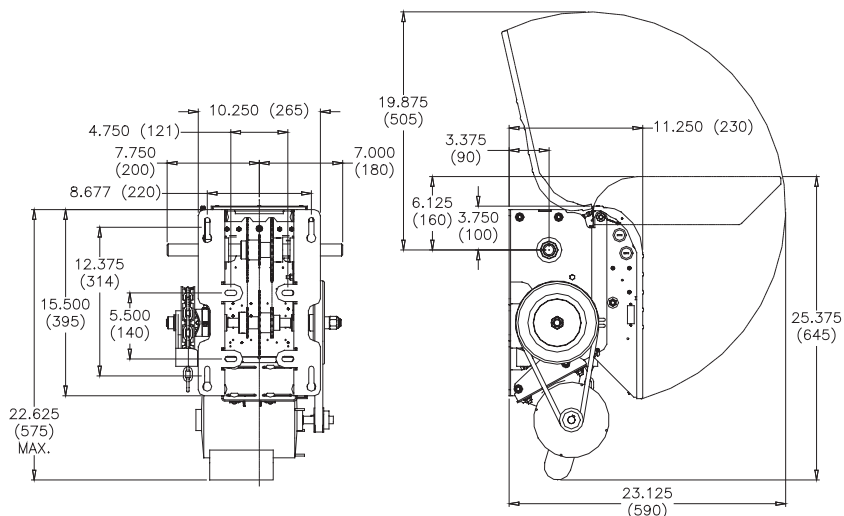

Manaras Opera SS./12/2001 printed in Canada

Motor Selection

Maximum Size of Door in Square Feet

Horse Power	Rolling Doors					Sectional Doors				
	Insulated steel	16 ga. steel	Steel Grilles 20 ga. steel	Alu. Door 22 ga. steel	Alu. Grilles 24 ga. steel	Steel 18 ga. ins.	Steel 18 ga. 20 ga. ins.	Wood steel 20 ga. 22 & 24 ga. ins.	Aluminium Steel 22 & 24 ga.	Fiber Glass
1/3	-	-	-	-	-	124	172	255	280	294
1/2	157	236	260	319	358	196	245	314	343	392
3/4	206	294	358	451	515	270	319	441	490	549
1	255	358	446	574	613	294	392	490	564	613

Clearance: Side room required 15" (380mm)

US toll free number: 866 - 776 - 7372
 Canada toll free number: 800 - 361 - 2260

Manaras reserves the right to make specification or design changes with out prior notice.

